

PERFORMANCE PARAMETER



LEVER BLOCKS

The range of CT SERIES lever blocks is tough reliable and great value for money. There is a model to suit every need.

Ideal for the farmer, serious home handyman or professional user, it is so easy to use and is built to last, comes standard with grade 80 chain in 1.5metres some are available in 3metre lengths.

All of our CT series lever blocks have been designed to last and to meet and exceed the Australian standards AS1418.2 - 1997.

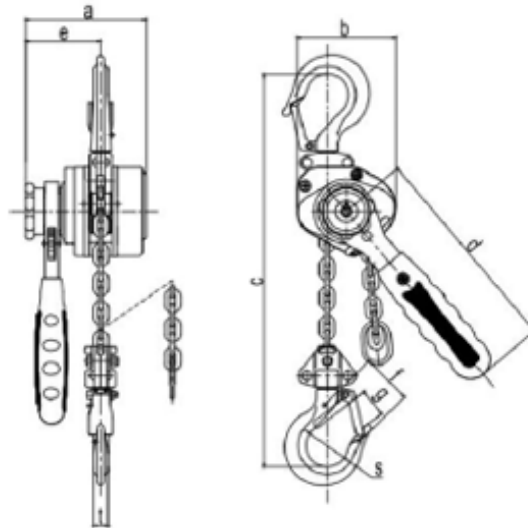

TECHNICAL PROPERTIES

Item No	W.L.L	Chain Grade	Chain Length	Unit Weight
CTLB80D	800kg	100	1.5m	5.7kg
CTLB160	1600kg	100	1.5m	8kg
CTLB163	1600kg	100	3m	9.6kg
CTLB320	3200kg	100	1.5m	13.6kg
CTLB323	3200kg	100	3m	17kg